

ZAMA CUBE CARBURETOR DISASSEMBLY AND SERVICE

MIXTURE SCREWS

- Remove idle and main mixture screw.
- Inspect each screw for damage, especially the needle points which should have no deformation of the tapered surfaces.
- A damaged needle or seat will result in a very sensitive needle. The needles will be difficult to adjust and the carburetor will always run too rich or too lean.

Note: On dual needle carburetors the L and H needle are not interchangeable. Remember that the L needle is always longer.



FUEL PUMP

FOR LA/LB TYPE:

- Remove fuel strainer cover and strainer.
- Remove pump diaphragm and pump gasket.
- Inspect pump diaphragm, replace if diaphragm shows any signs of wear or curling.
- Remove metering chamber cover.
- Remove metering diaphragm and metering chamber gasket.
- Inspect metering diaphragm for dirt and foreign matter. Remove pump cover screws and pump cover.

FOR ALL OTHER TYPES: C1U, C1Q/M, C2, C3, C3A/M

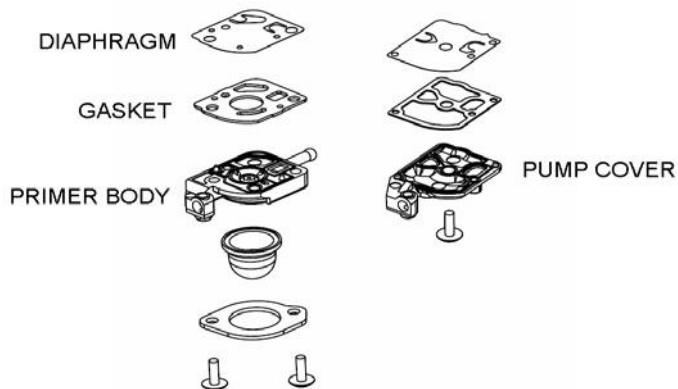

- Remove pump cover screws and pump cover or primer body.
- Remove pump gasket and pump diaphragm.
- Inspect pump diaphragm, replace if diaphragm shows any signs of wear, wrinkles or tears.
- Remove strainer.

METERING DIAPHRAGM

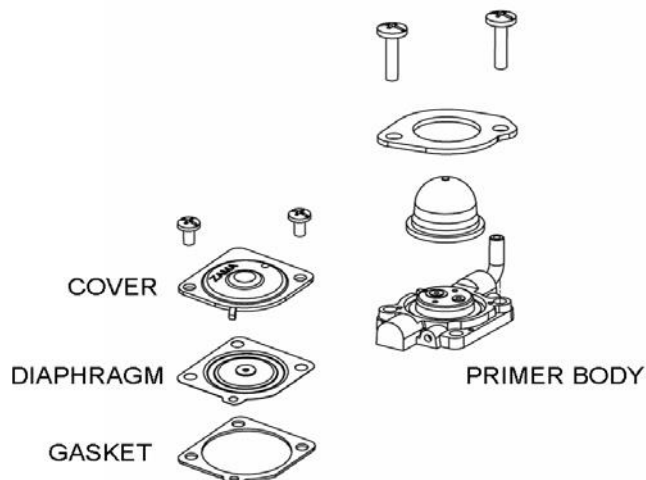

- Remove screws and metering chamber cover or primer body.
- If metering diaphragm is hooked type, remove it, being careful to un-hook it from metering lever.
- Remove metering chamber gasket.
- Inspect metering diaphragm for dirt and foreign matter.

INLET NEEDLE VALVE

- If the carburetor is equipped with a plastic metering disk, remove it carefully. The disk must be smooth and free from cracks or chipped edges. The center tip that fits into the metering lever hole must be secure and not broken or worn.
- The following instructions apply to all models.
- Remove metering lever screw.
- Remove metering lever, pin, metering lever spring and inlet needle valve.
- Inspect the metering lever. It should not be worn where it contacts the inlet needle valve and metering disk.
- Inspect inlet needle valve. The tip should not be deformed where it contacts the seat.

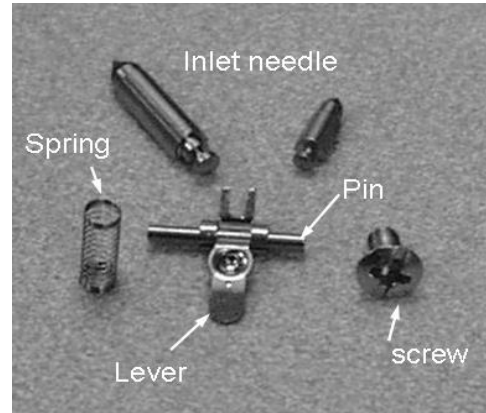
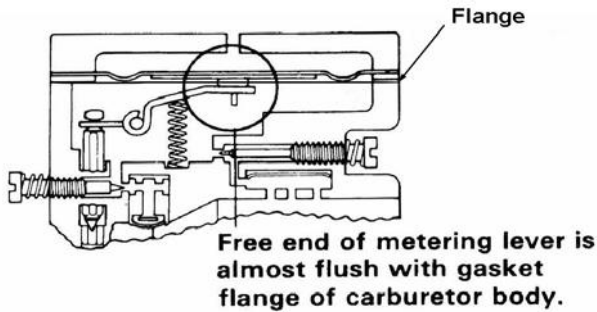

WELCH PLUG

- Under the extreme conditions of a clogged idle port and channel, it may be necessary to remove the welch plug. Do this operation very carefully. If the carburetor is equipped with the priming pump, do not attempt to remove the welch plug unless you are certain the check valve in the idle chamber is malfunctioning.
- Use a small 2/32 to 3/32 inch diameter sharp pointed punch to pierce the welch plug.
- Just below the welch plug there is a thin casting wall where the idle and secondary holes are located. Punching through this area will ruin the carburetor body casting. Let the punch just pierce the welch plug, then carefully pry the welch plug out of the body casting.
- If the carburetor is equipped with the plastic filling in the idle chamber, it will be unusable when the welch plug is removed.

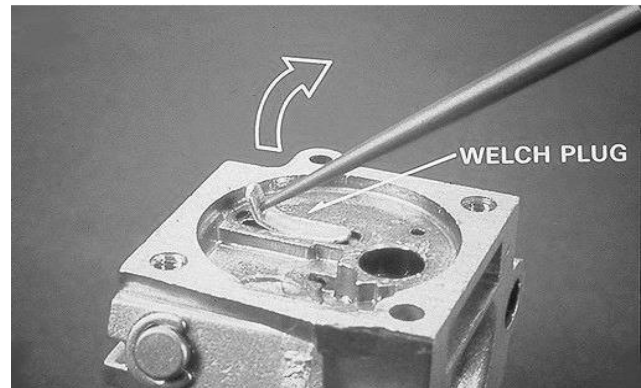

Note: It is often un-necessary to remove the welch plug. Test for plugged progression holes by spraying carb cleaner into the L needle hole. If cleaner sprays out the progression holes there is no need to remove the welch plug.

LOCATION CHART FOR PIERCING WELCH PLUGS

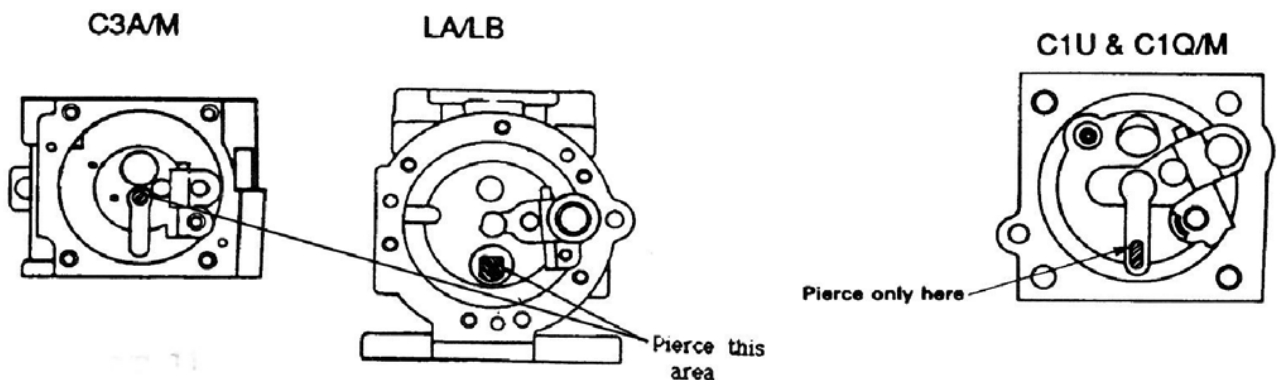

NOZZLE

- Test the main nozzle by blowing air by mouth through the H needle feed hole with a small hose. With the needle open 2 turns open air should flow through, but you should not be able to suck air back.
- Before removing nozzle assembly, make sure the main mixture screw was already removed.
- If the carburetor is equipped with a pressed in nozzle assembly, do not attempt to remove it unless you are certain it is malfunctioning. If it is necessary to remove, carefully press it out with steel rod or punch slightly smaller in diameter than the nozzle.
- If the carburetor is equipped with a screw in nozzle assembly, remove it in the same manner as a normal screw.
- If the carburetor is equipped with strainer and C-ring type, remove main welch plug, then remove C-ring and retainer. It is not necessary to remove nozzle.
- The strainer and retainer type is not repairable. Clean them using gasoline and compressed air.

CARBURETOR BODY

- Clean the carburetor body. Channels can be cleaned by blowing through the idle and main adjusting orifices with spray carburetor cleaner. Do not soak in dip tank type cleaner. Do not use wires or drills to clean orifices. Inspect the operation of the throttle valve and lever.

REASSEMBLY

- * Replace all worn parts and make sure that all parts are clean before they are reassembled into carburetor body.

NOZZLE

- Make sure the main mixture screw was removed, before reassembling the nozzle assembly.
- If nozzle assembly is a pressed in type, put a light oil film on the outside of the nozzle check valve cage.
- Carefully press the nozzle into the carburetor body until it is just flush with the metering chamber.
- If the carburetor is a strainer and C-ring type, install the strainer and C-ring. Lay the main welch plug into the cavity and press it firmly with a flat end punch to expand it tightly against the sides of the cavity.
- If nozzle assembly is a screw in type, reassemble in the same manner as a normal screw.

WELCH PLUG

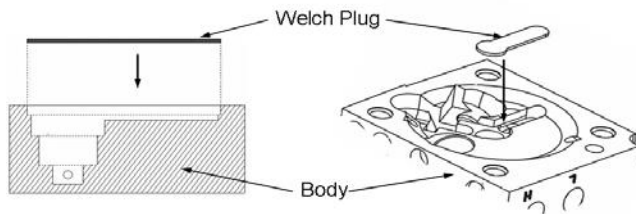

- Lay the welch plug into the cavity. If the welch plug is circle shape, press it firmly with a flat end punch to expand it tightly against the sides of the cavity. If the welch plug is oblong shape, press it firmly with oblong punch.
- Lay the welch plug into the cavity. Press it firmly with oblong punch. It is best to use sealer for sealing around the welch plug.

INLET NEEDLE VALVE



- Inspect the metering lever and the pin.
- Assemble the lever onto the pin and rotate the pin. The lever should fit easily on the pin and not stick.
- Install the inlet needle valve, metering spring, metering lever, pin and retaining screw.
- Adjusting the metering lever. The Zama "Z" gauge is designed to adjust all models. Hold the gauge against the body as shown using the proper side designated for the model you are adjusting. The end of the metering lever should touch the gauge. A straight edge can also be used as described on the next page.

(A) If the metering lever is the same as Figure a in the following schematic, place a straight edge or Zama Z gauge across the carburetor body. The free end of the metering lever should be 0 to 0.3 mm - 0 to 0.012" below the straight edge.

(B) If the metering lever is the same as Figure b in the following schematic, the free end of the metering lever should be flush with the cavity floor. (1.7mm to 2.0 mm - 0.067" to 0.078" below the metering gasket flange of carburetor body).



ADJUSTING THE METERING LEVER HEIGHT

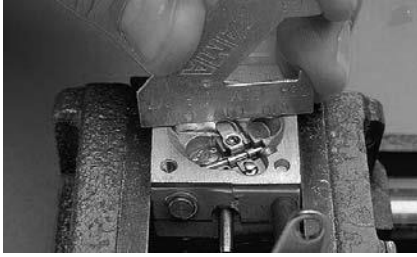

Zama Z-gauge

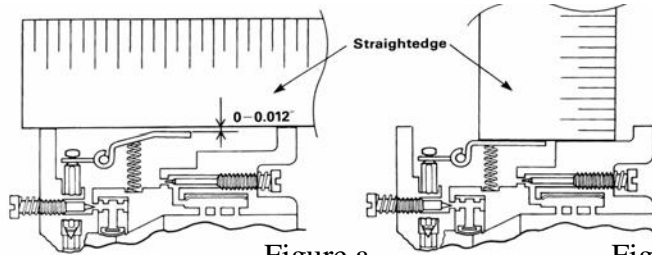
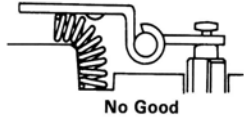

Figure a

Figure b

If the metering lever is too high, push down on the free end of the lever, then carefully push down on the inlet needle, if the metering lever is too low, pry up carefully on the free end of the lever.



No Good

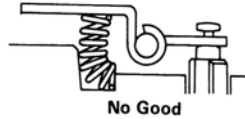

No Good

- Make sure the metering lever spring is seated at the bottom of the casting pocket and under the dimple in the metering lever.

Push down here

Then push down needle here

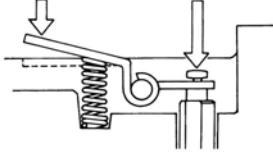

High

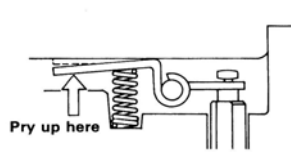

Low

- If the metering lever is too high, push down on the free end of the lever, then carefully push down on the inlet needle, if the metering lever is too low, pry up carefully on the free end of the lever.



METERING DIAPHRAGM AND FUEL PUMP

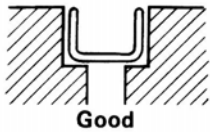

Good

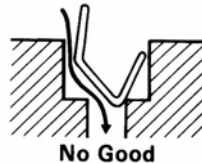

No Good

- Install the fuel strainer to the pump cover using a flat end punch of a diameter nearly equal to the inside of the strainer.



METERING CHAMBER FOR ALL CUBE TYPES: C1U, C1Q/M, C2, C3, C3A/M

METERING CHAMBER COVER

METERING DIAPHRAGM

METERING CHAMBER GASKET

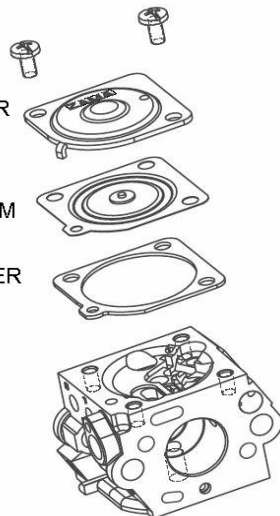

- If the carburetor is equipped with a plastic disk, install it onto the metering lever by placing the molded tip into the hole in the free end of the metering lever.
- Install the metering chamber gasket, metering diaphragm, metering chamber cover and screws. Metering chamber gasket and metering diaphragm should be assembled in the proper order.
- Install the fuel strainer using a flat end punch of a diameter nearly equal to the inside of the strainer. Push the screen straight into the casting to the bottom of the bore.

FUEL PUMP FOR ALL CUBE TYPES: C1U, C1Q/M, C2, C3, C3A/M

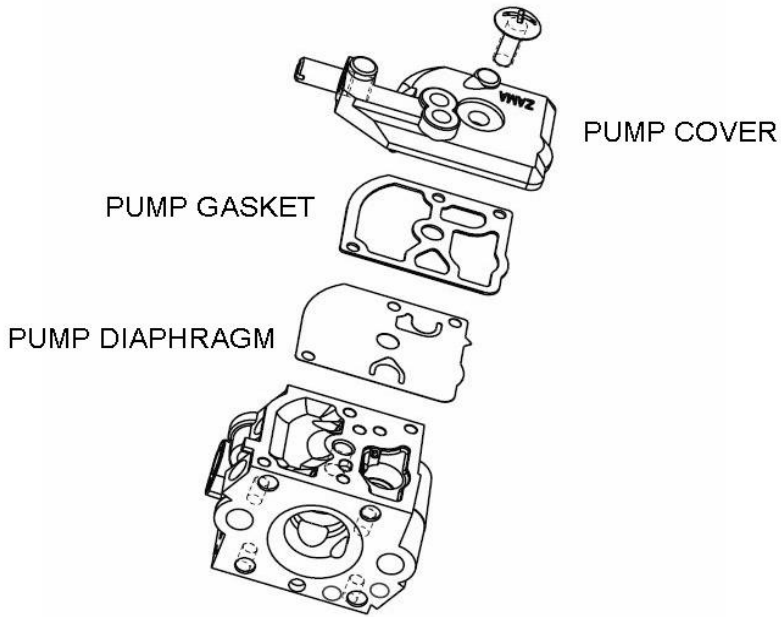

- Install the pump diaphragm, pump gasket, pump cover and screw. Pump diaphragm and pump gasket should be assembled in the proper order.

METERING DIAPHRAGM AND PUMP FOR LA/LB TYPE:

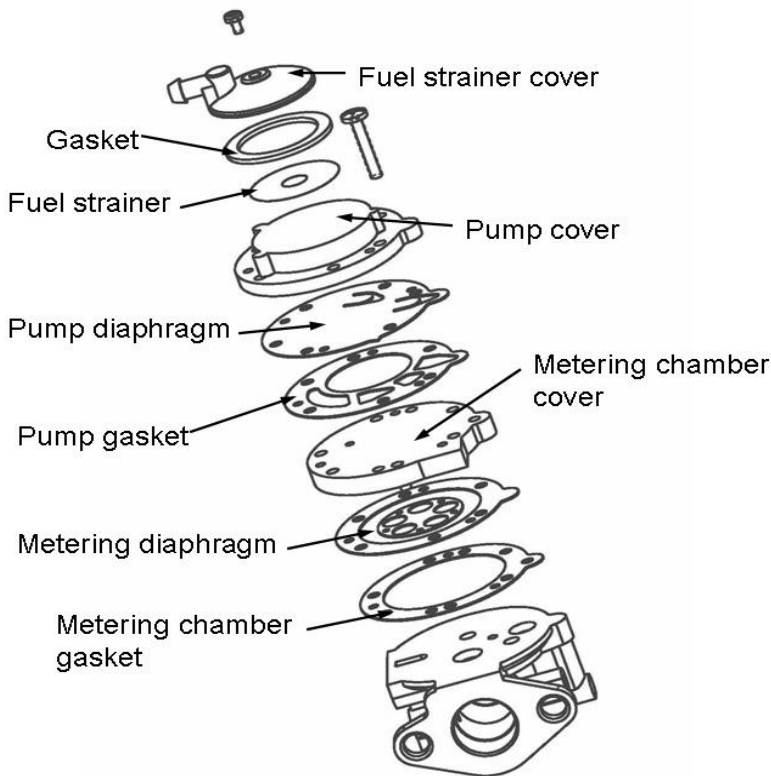

- Install the metering chamber gasket, metering diaphragm, and metering chamber cover. Metering chamber gasket, and metering diaphragm should be assembled in proper order.
- Install the pump gasket, pump diaphragm and pump cover. Pump gasket and pump diaphragm should be assembled in proper order.
- Carefully install the fuel strainer. Push the screen straight into the casting to the bottom of the counter bore. Install the gasket, fuel strainer cover and screw.